

## Universal Hydraulic Bale Clamp

The *Cashels Universal Hydraulic Bale Clamp* has been developed mainly for handling wrapped, rectangular and round bales of silage.

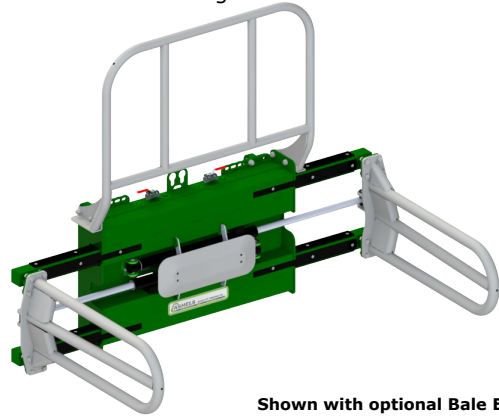

Shown with optional Bale Extension fitted.

With a clamping range from 750mm (30") to 2050mm (81"), the Bale Clamp can handle various bale types and sizes without causing damage to the bale film. It is also suitable for handling unwrapped bales of straw, haylage, hay and waste materials. Larger model available also (see details below).

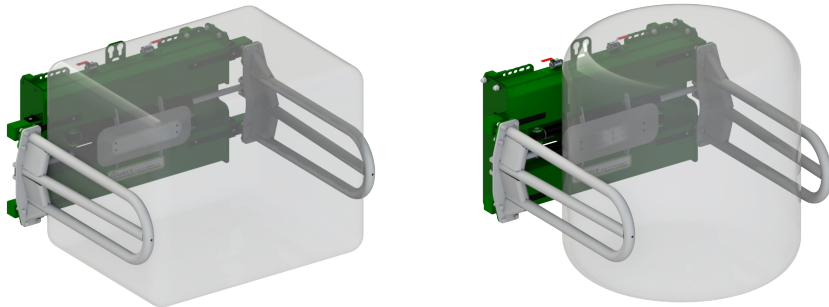

### Key Features:

- Unique, robustly constructed frame design with bolt-on clamping arms.
- Heavy-duty hydraulic cylinders with built-in check valves.
- Maintenance free, self-lubricating wear pads.
- Optional bolt-on bale extension.
- Hot-dip galvanised clamping arms.
- Various linkage options available.

## Universal Hydraulic Bale Clamp

Smooth movement and longevity of the telescopic mechanism is guaranteed by the use of self-lubricating wear pads. The robust construction of the clamping arms in conjunction with the heavy-duty cylinders and built-in check valves ensures ample and secure clamping force. The hydraulic configuration allows either clamping arm to be locked in position while allowing the other clamping arm to be independently operated.

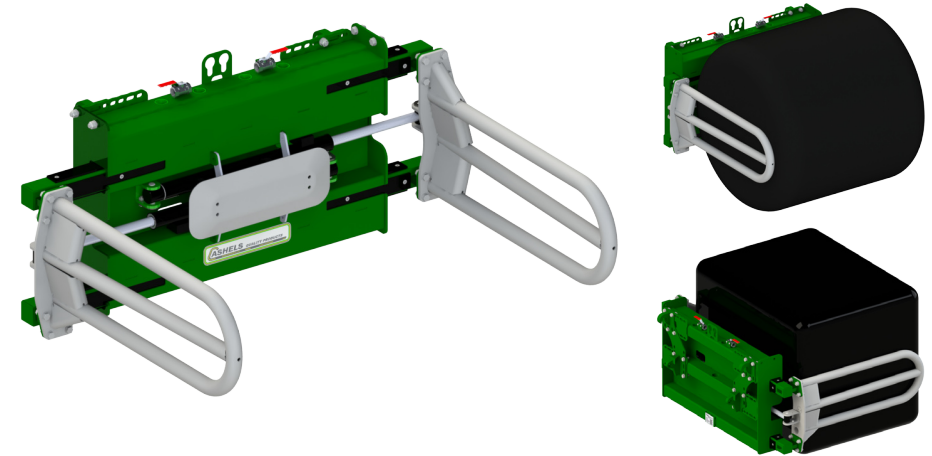

### Handling Options Available

1. Arms with rollers for handling 4-6ft wrapped round bales.
2. Arms with CAT 2 tines for spiking and clamping all bale types during the feeding season. See Fig.1a-2c below.

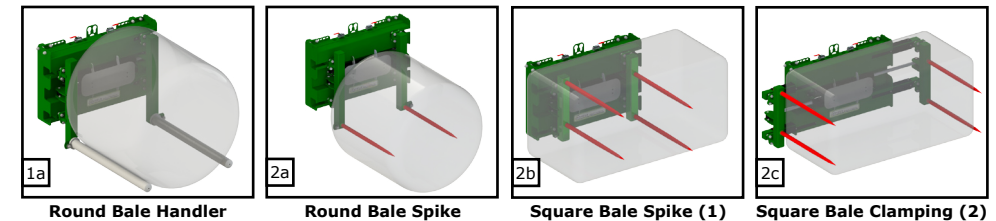

Model	Length	Width	Height	Linkage	Load Capacity	Net Weight	Max Opening	Max Closed	Tractor HP
CIUHBC	1400mm (55")	1220mm (48")	760mm (30")	EURO	1 Bale 1500kg (3300lbs)	340kg (748lbs)	2050mm (81")	750mm (30")	60+
CIUHBC2	1400mm (55")	1620mm (64")	760mm (30")	EURO	1 Bales 1500kg (3300lbs)	395kg (869lbs)	2450mm (96")	1150mm (45")	60+