

Pick & Stack Double Bale Handler

The Cashels **Pick & Stack Double Bale Handler** is designed for transporting and stacking two wrapped, round bales. Available in 4ft and 5ft models, the **Pick & Stack Double Bale Handler** is designed to minimise the time from field to storage area, without compromise to the bale integrity. A hydraulic top link is required when operating the **Pick & Stack Double Bale Handler**.

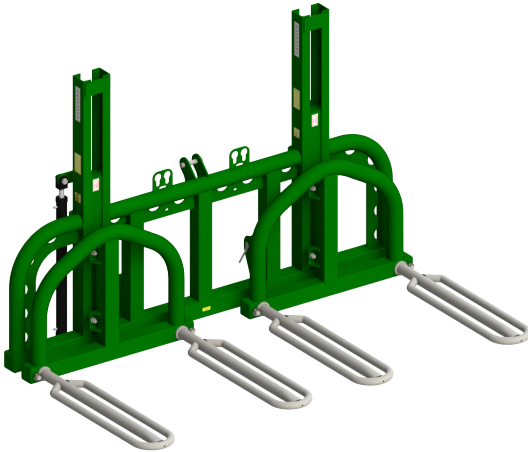

Both sides of this product can be independently moved using heavy duty hydraulic cylinders.

This allows the operator to lift the first bale, while lowering the implement to collect the second without tearing the plastic of the first bale.

Bales can be tipped onto their flat end by dropping the bale handler to the ground, driving forward approximately $\frac{3}{4}$ of the bale length and then raising the lift arms.

As the lift arms are raised, the paddles rotate and the bale will stand on its end without any damage to the bale

film. The bales can then be stacked two-high as shown in Fig. 1. The unit is also designed for loading/unloading bales to and from a bale trailer.

Key Features:

- Transports and stacks two round bales.
- Loads & unloads bales to and from a bale trailer.
- Handles mature bales during feeding season.
- Handles misshapen/sagged bales.
- Heavy duty construction throughout.
- Available in a 4ft and 5ft model.

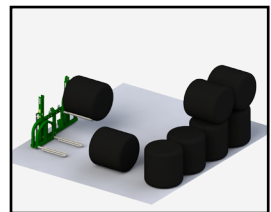
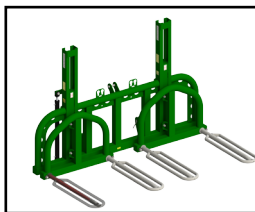

Fig. 1

See video on www.cashels.net

Model	Length	Width	Max Lift Height	Linkage	Load Capacity	Net Weight	Tractor HP
4ft	1390mm (55")	2500mm (98")	1250mm (49")	CAT 2	2 Bales 1500kg (3300lbs)	450kg (990lbs)	100+
5ft	1500mm (59")	2935mm (116")	1250mm (49")	CAT 2	2 Bales 2000kg (4400lbs)	480kg (1056lbs)	100+