

Hydraulic Bale Handler

The **Hydraulic Bale Handler** has been designed to handle, transport and stack wrapped round bales. Designed for use on tractor loaders and front/rear 3-point linkage of tractors (*not suitable for use on farm/industrial loaders*).

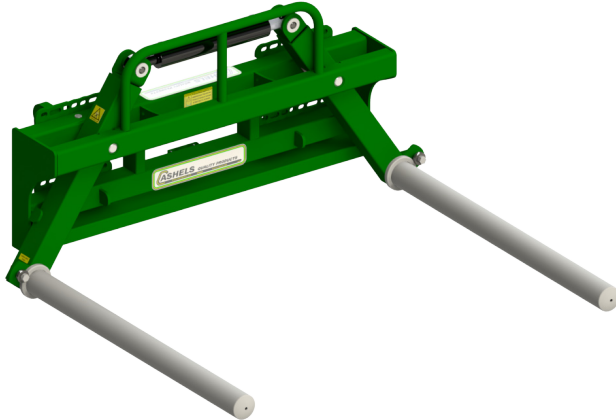

Key Features:

- Robust construction with high quality paint finish.
- 43" CAT 2 stone fork tines fitted with rotating tubes to ensure no film damage.
- Rotating tubes are easily removed, allowing the unit to be used for spiking bales during the feeding season.
- Hot-dip galvanised roller tubes.
- Various linkage options available.

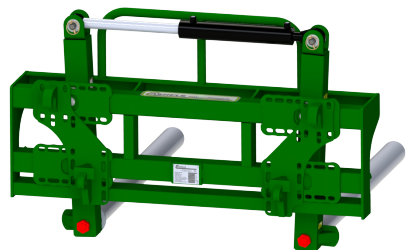
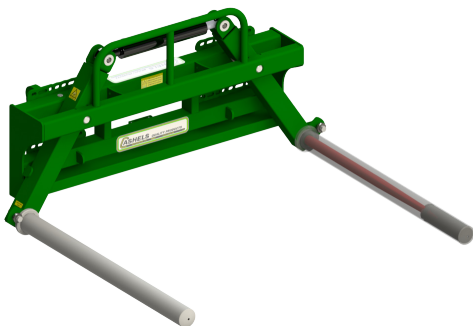

Length	Width	Height	Linkage	Load Capacity	Net Weight	Tractor HP
1410mm (56")	1380mm (54")	885mm (35")	EURO	1 Bale 1000kg (2200lbs)	195kg (429lbs)	60+